

ESTAMPA 1 – Penedo do Lexim. Cerâmica decorada.

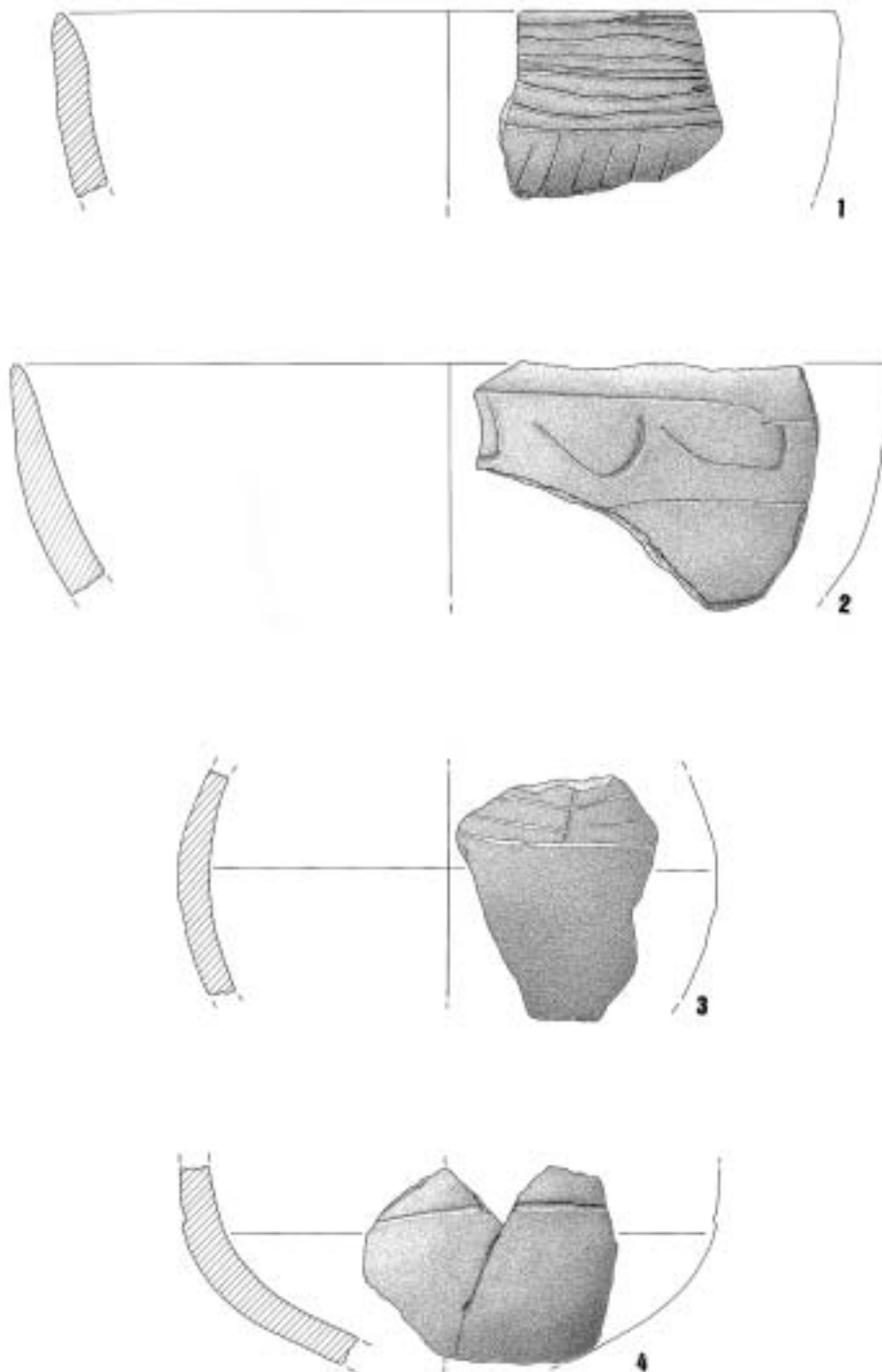

ESTAMPA 2 – Penedo do Lexim. Cerâmica decorada.

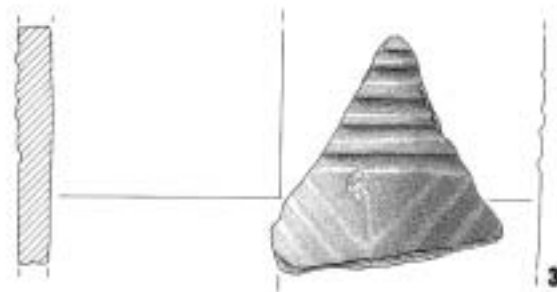
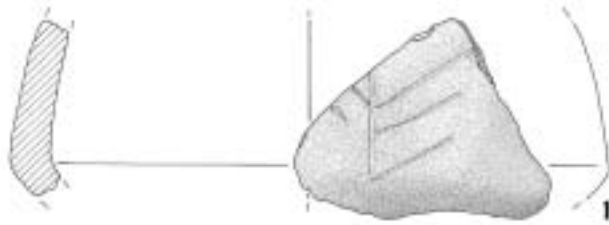

ESTAMPA 3 – Penedo do Lexim. Cerâmica decorada.

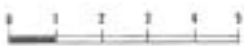
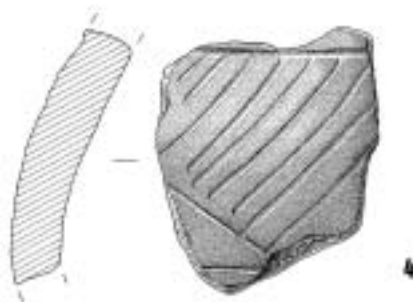
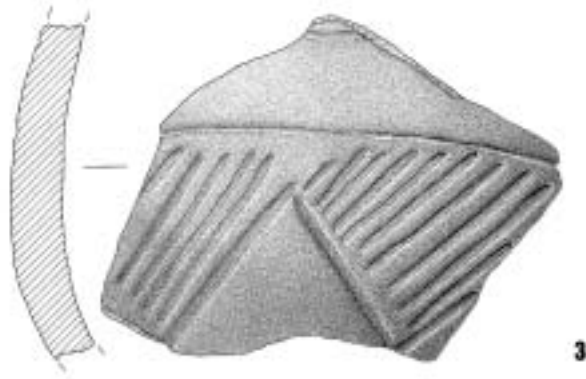
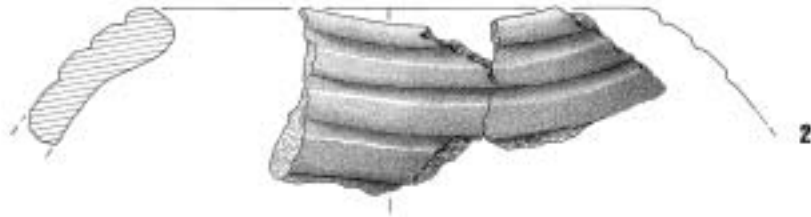
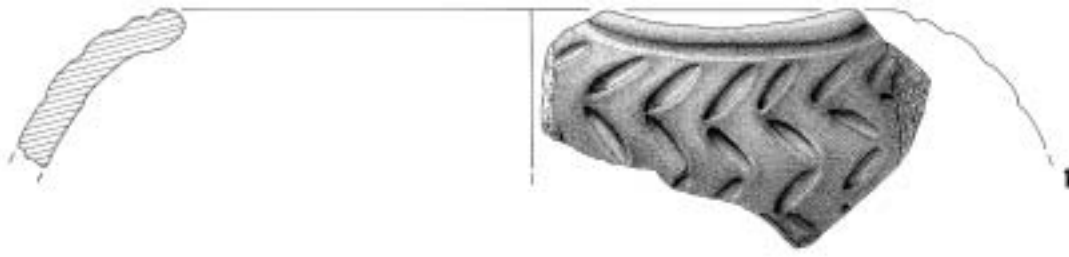

ESTAMPA 4 – Penedo do Lexim. Cerâmica decorada.

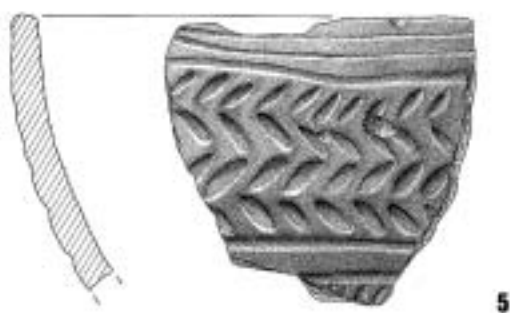
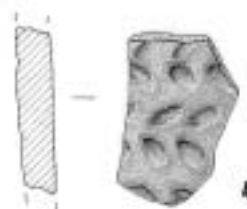

ESTAMPA 5 – Penedo do Lexim. Cerâmica decorada.

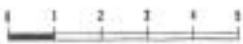
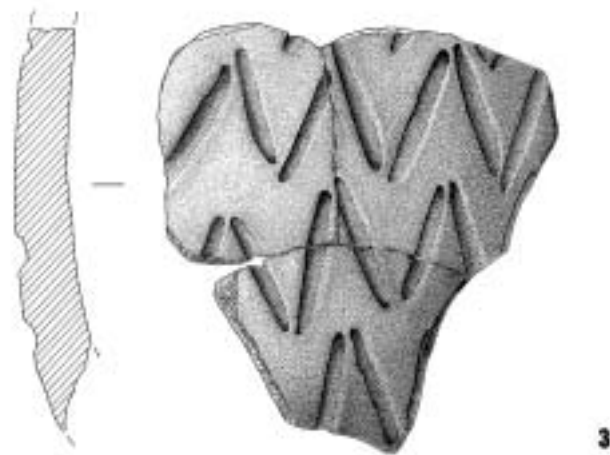
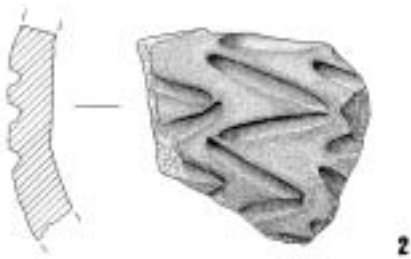

ESTAMPA 6 – Penedo do Lexim. Cerâmica decorada.

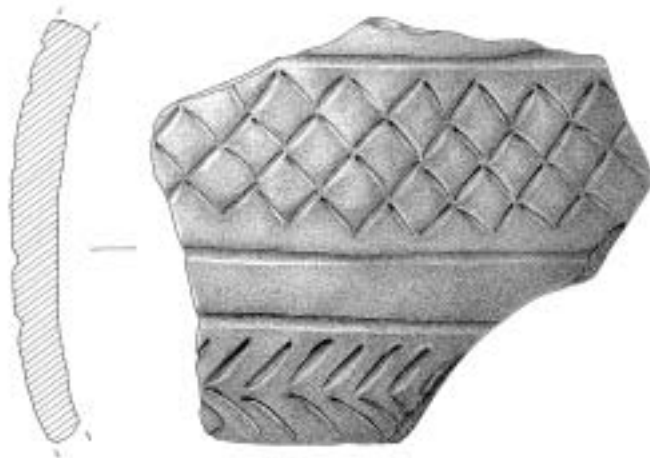

1

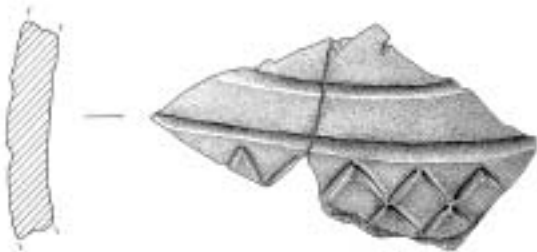

2

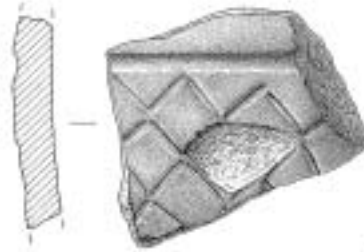

3



4

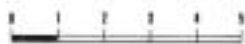

ESTAMPA 7 – Penedo do Lexim. Cerâmica decorada.



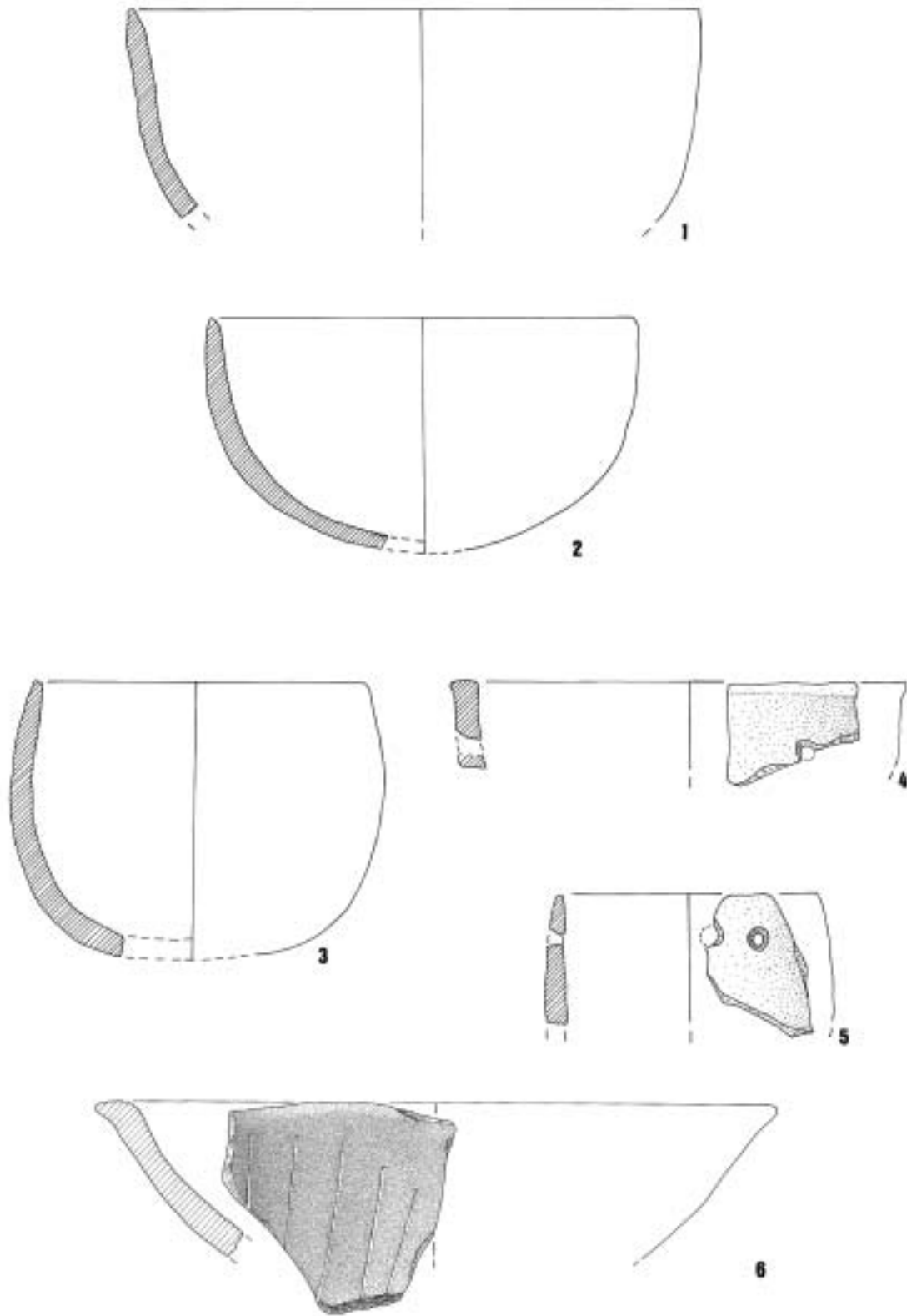

ESTAMPA 8 – Penedo do Lexim. Recipientes cerâmicos abertos.

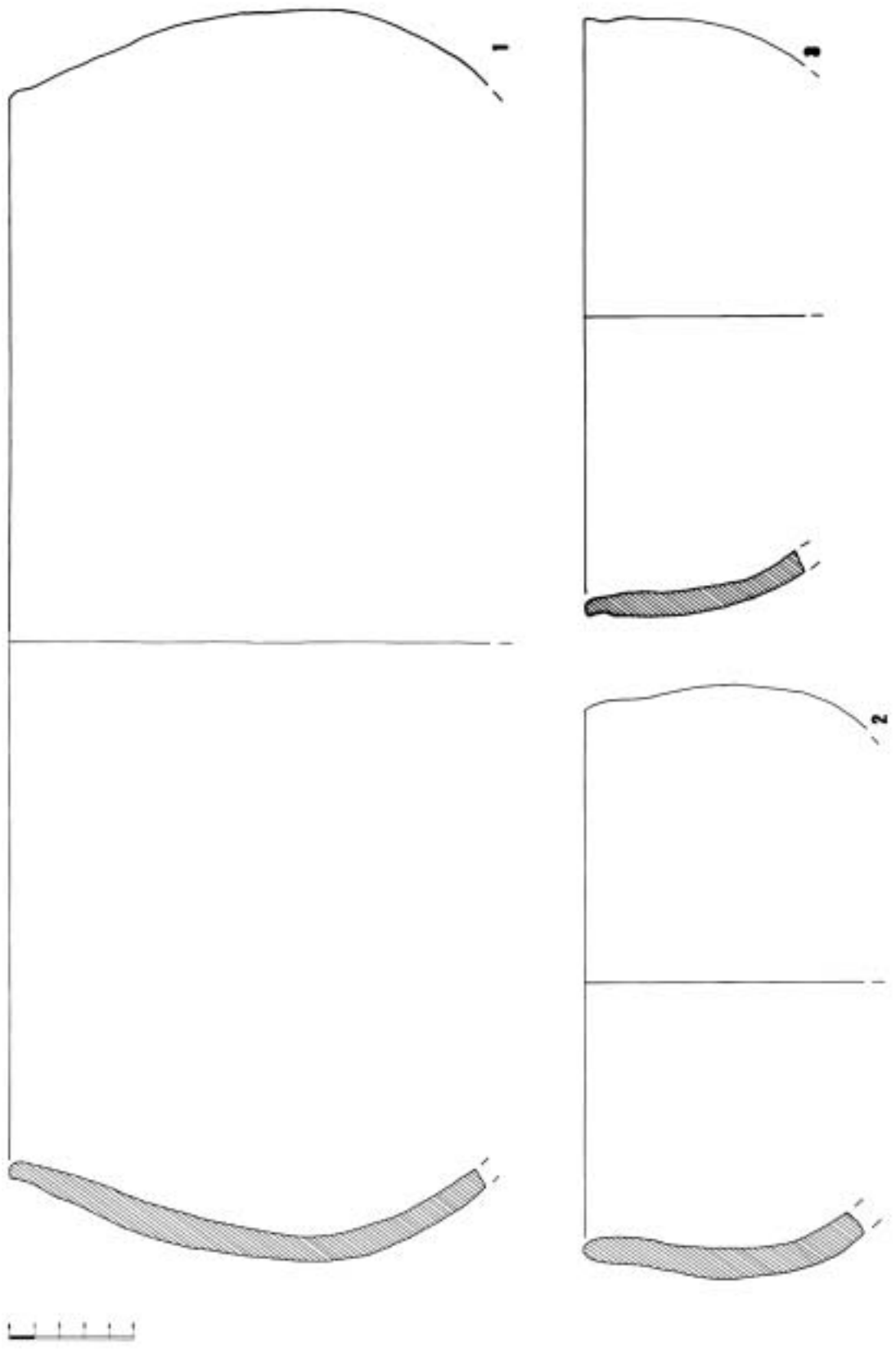

ESTAMPA 9 – Penedo do Lexim. Recipientes cerâmicos abertos.

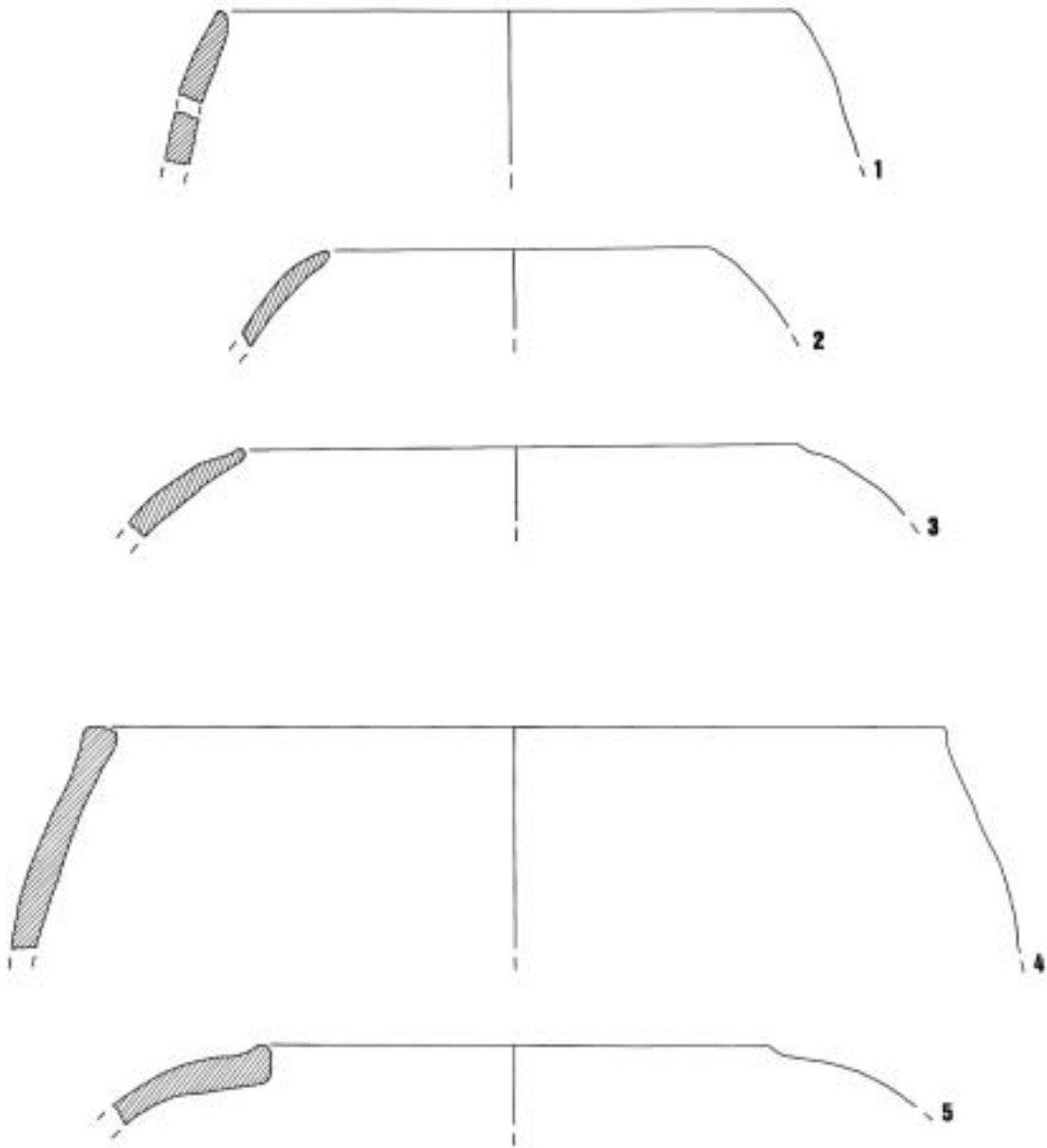

ESTAMPA 10 – Penedo do Lexim. Recipientes cerâmicos fechados.

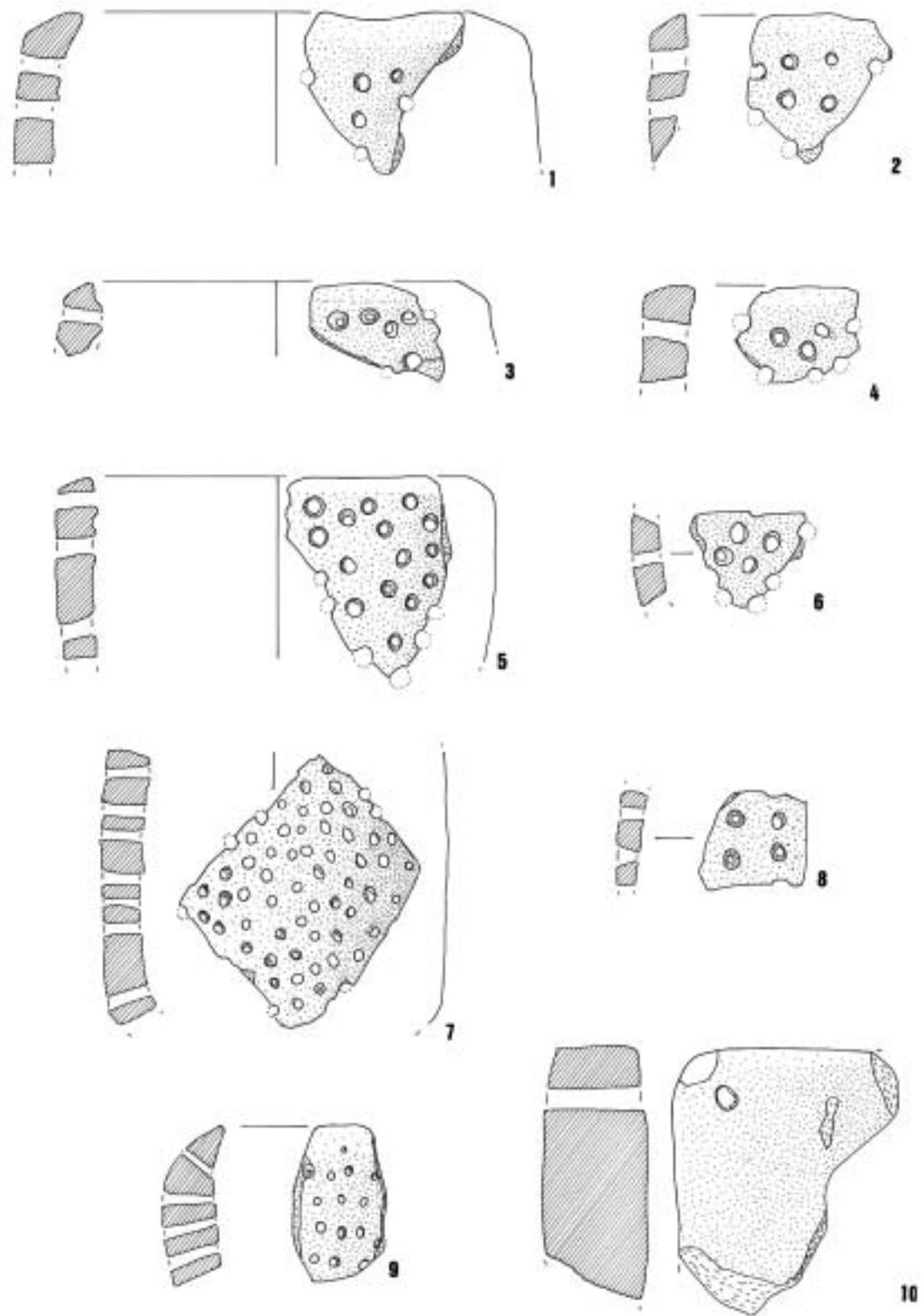

ESTAMPA II – Penedo do Lexim. Fragmentos de queijeira e peso de tear.

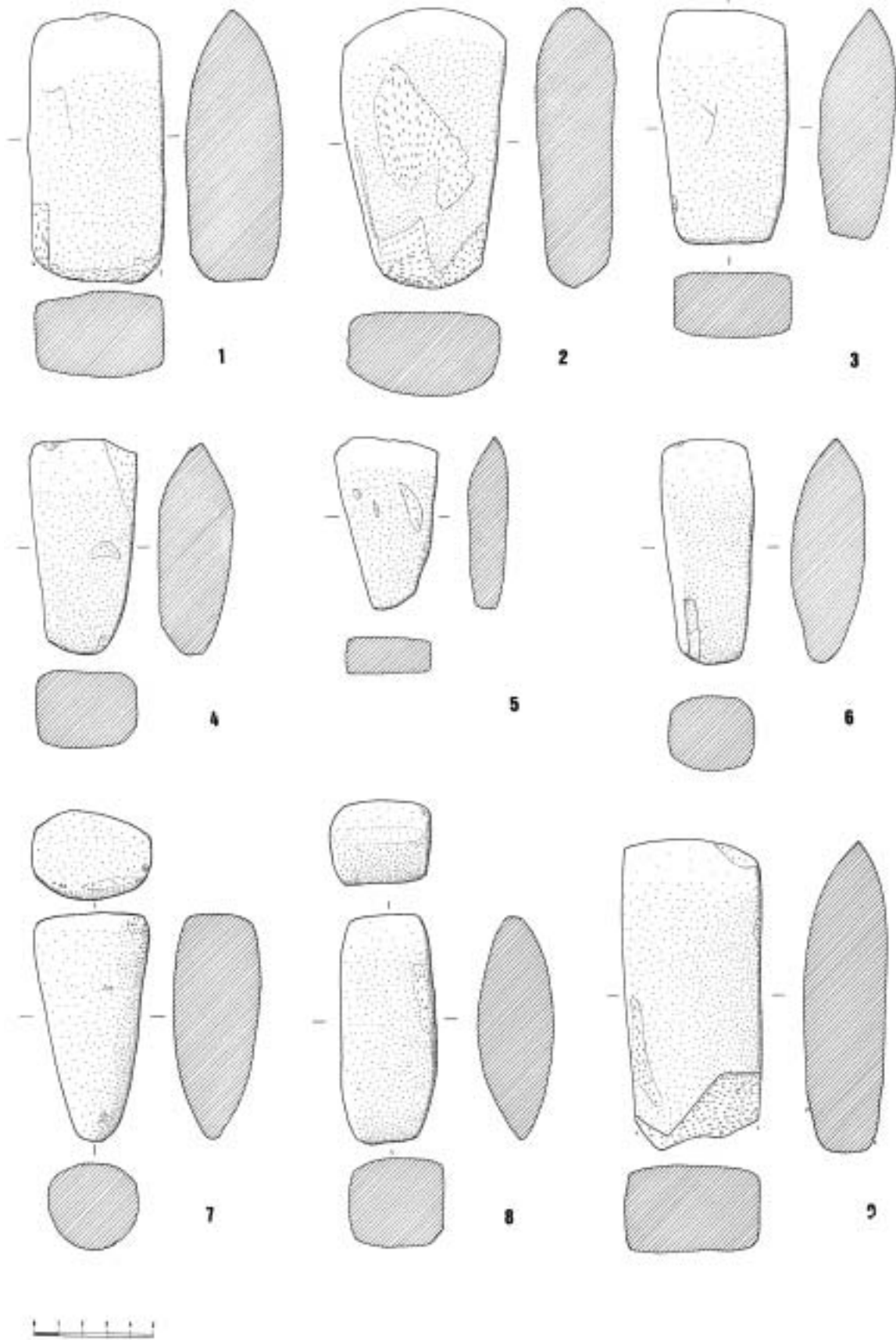

ESTAMPA 12 – Penedo do Lexim. Pedra polida.

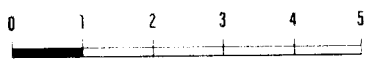
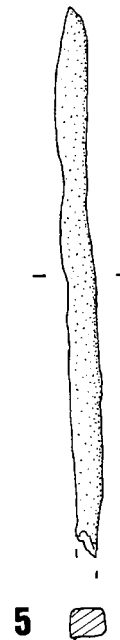
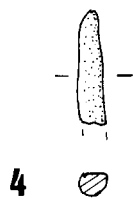
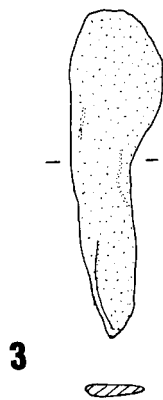
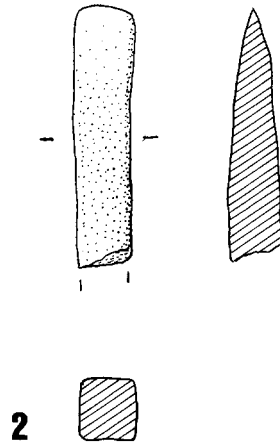
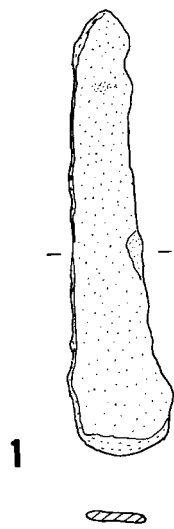

ESTAMPA 13 – Penedo do Lexim. Artefactos de metal.

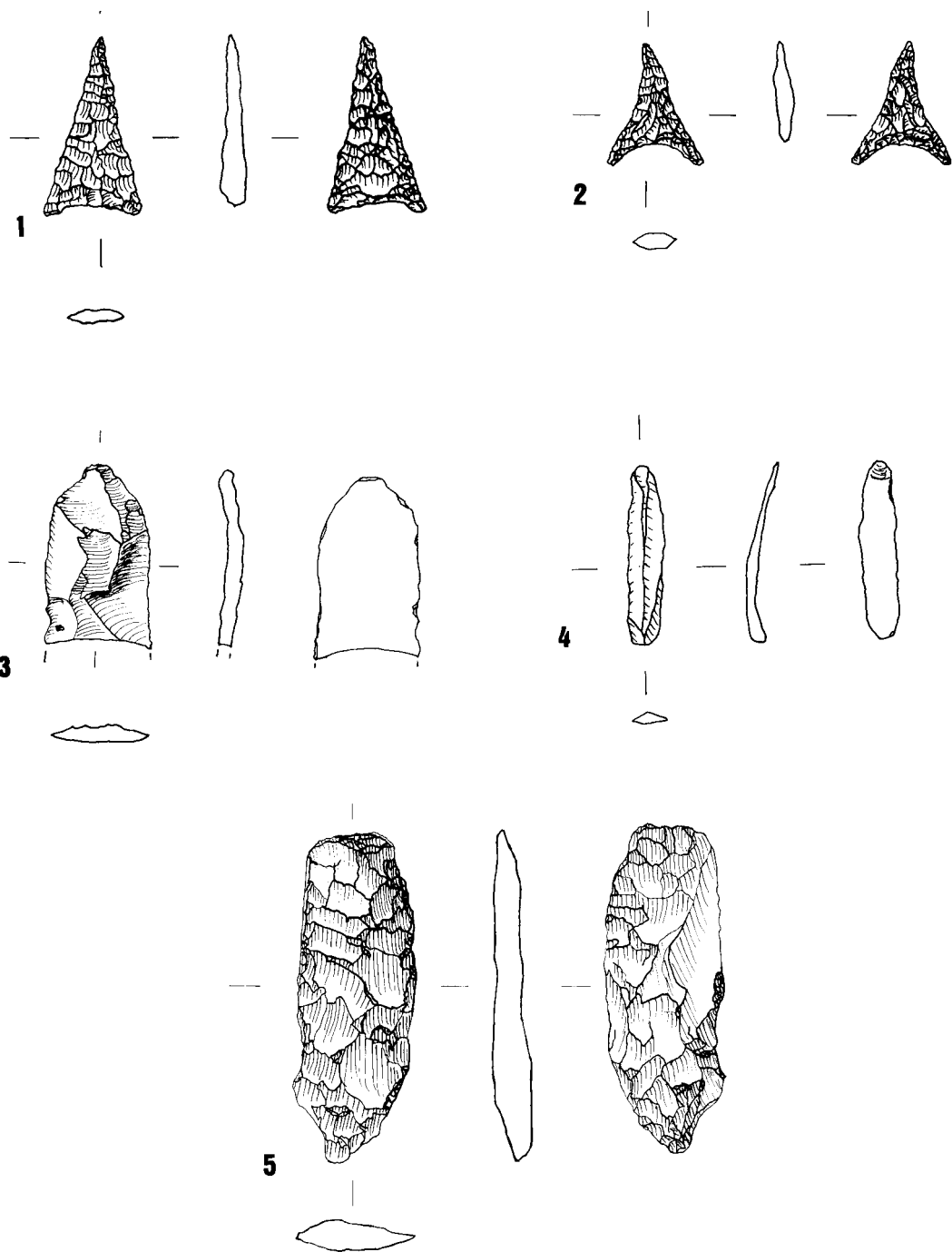

ESTAMPA 14 – Penedo do Lexim. Pedra lascada.

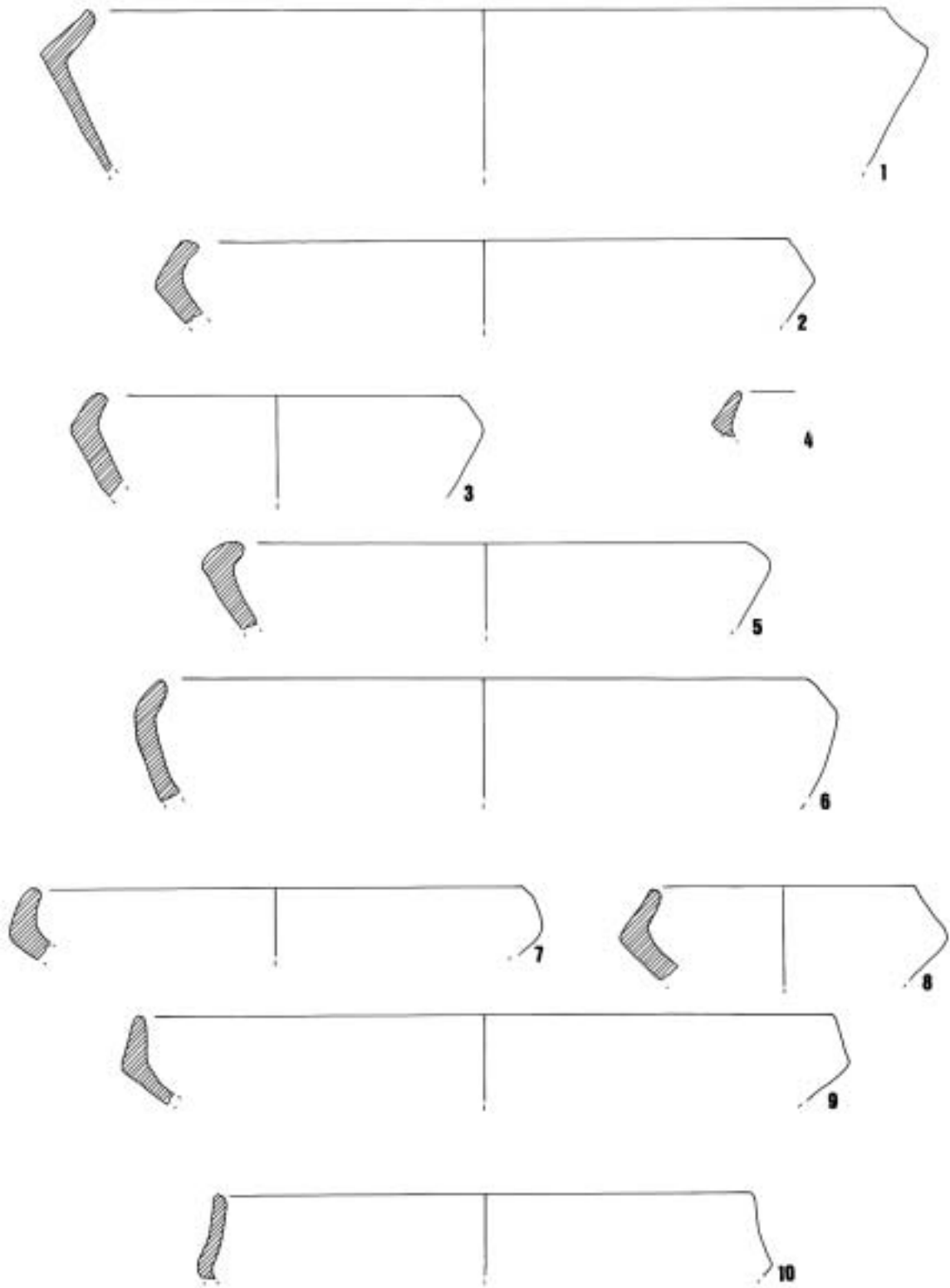

ESTAMPA 15 – Negrals. Taças carenadas.



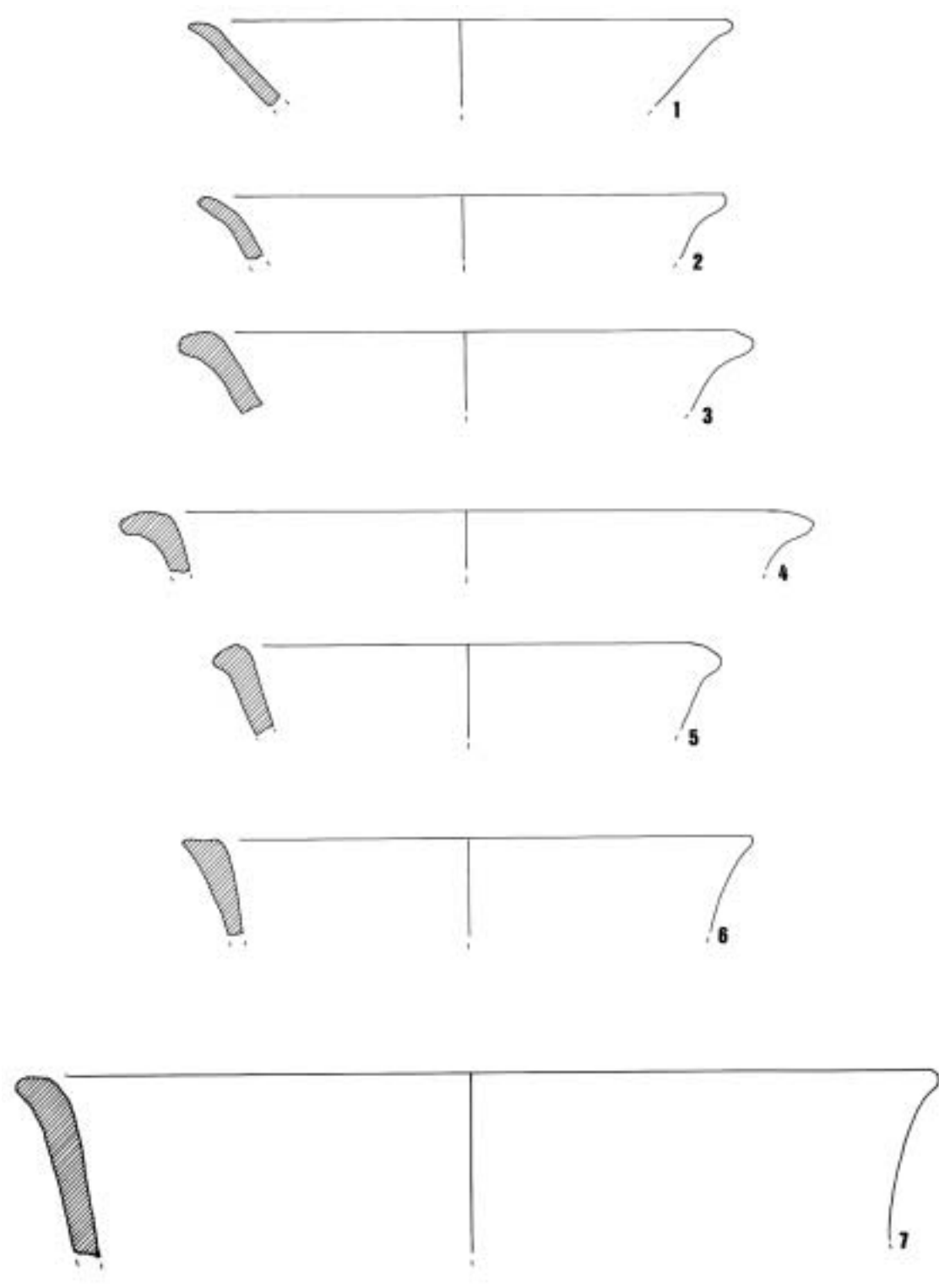

ESTAMPA 16 – Negrais. Taças.

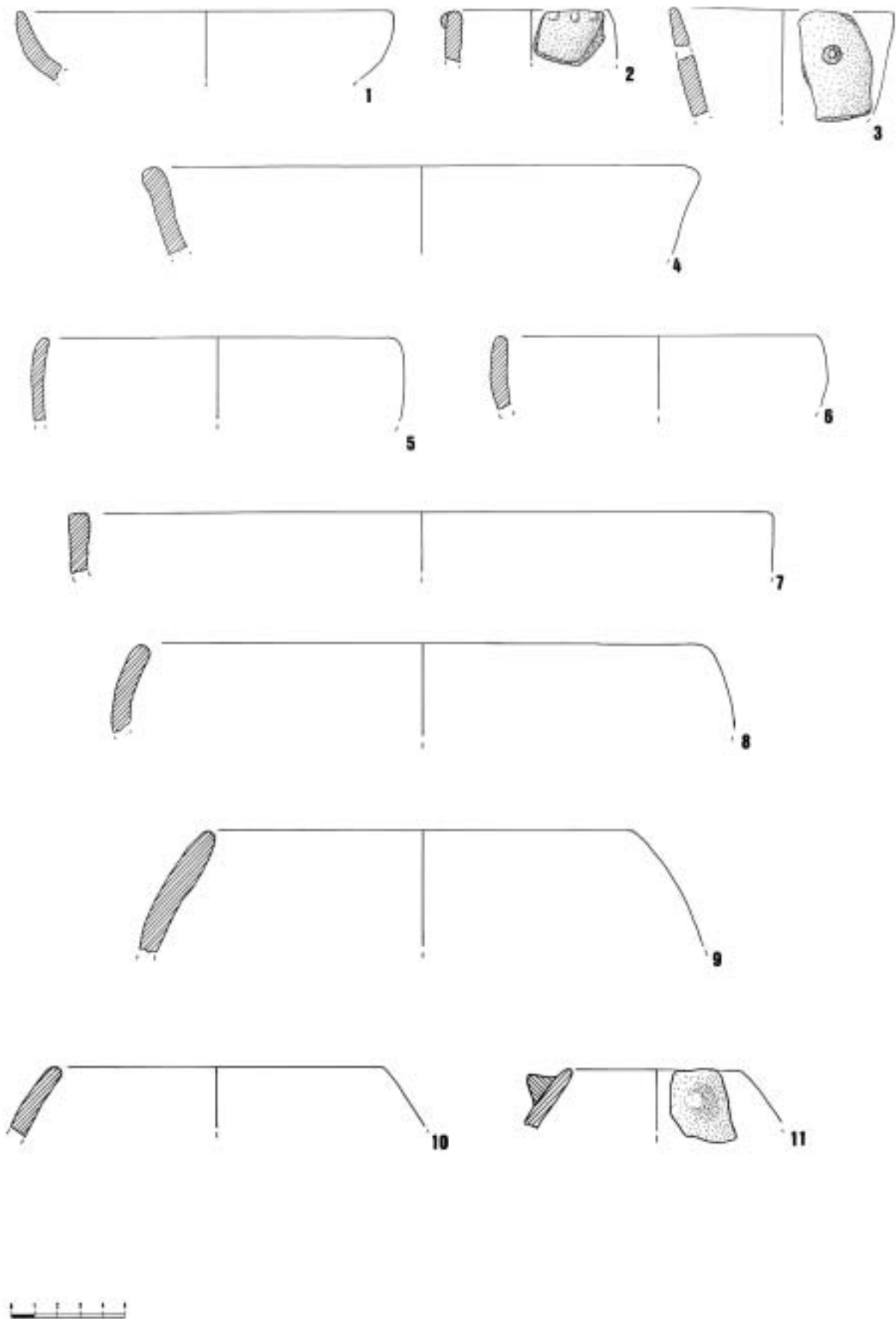

ESTAMPA 17 – Negrais. Formas abertas e fechadas. Negrais (recolhas de Cunha Serrão e Prescott Vicente sem outras indicações de proveniência), Negrais Barruncheiros: 3, 10, 11 e Negrais Pedraceiras: 3.

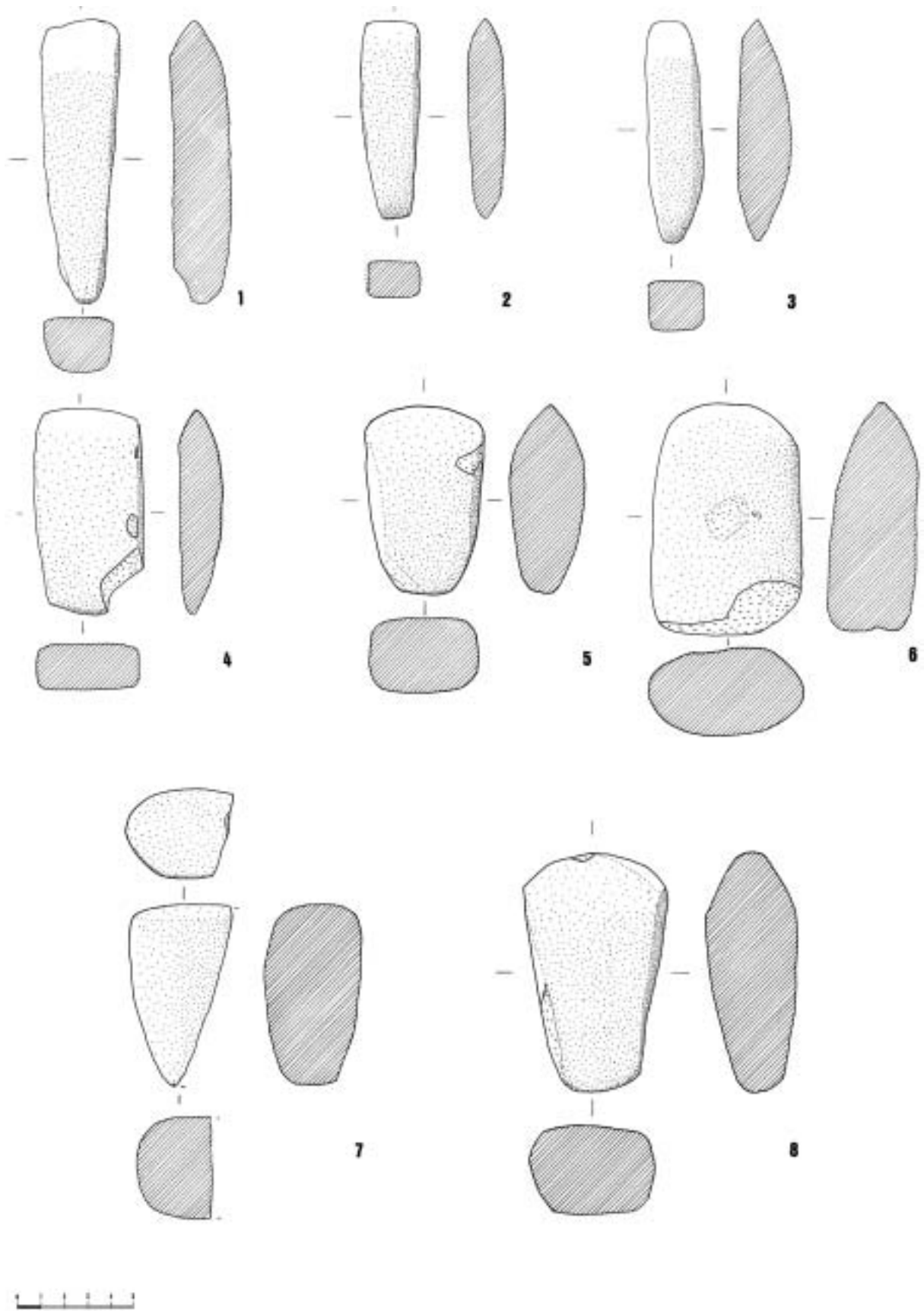

ESTAMPA 18 – Negrais. Pedra polida.

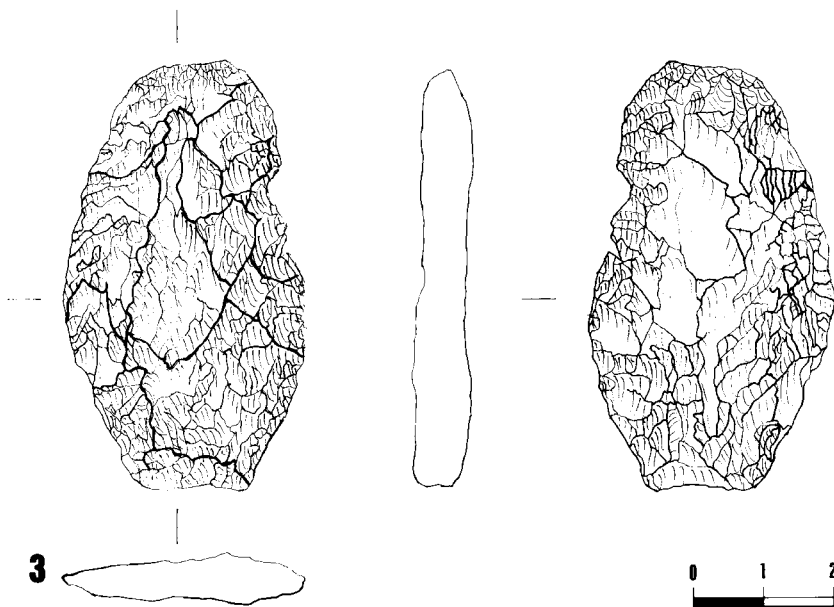
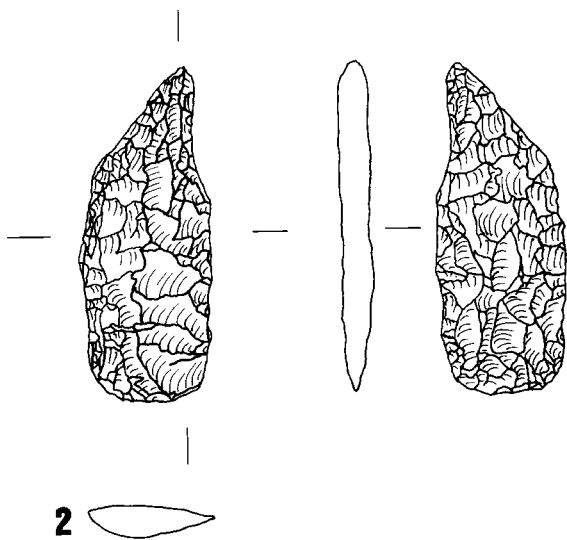
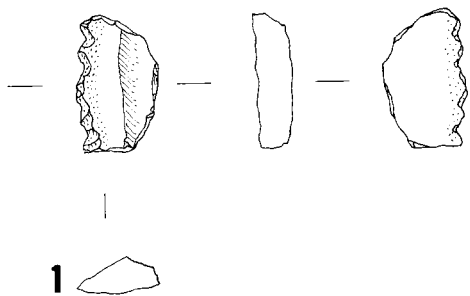

ESTAMPA 19 – Negrais. Pedra lascada.

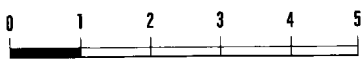
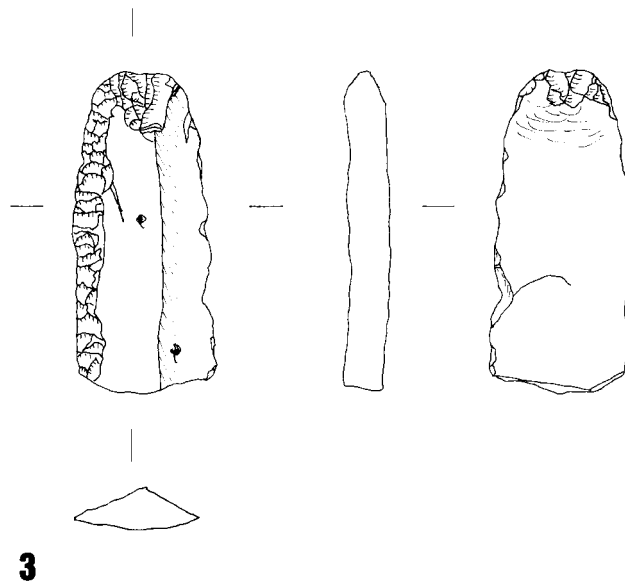
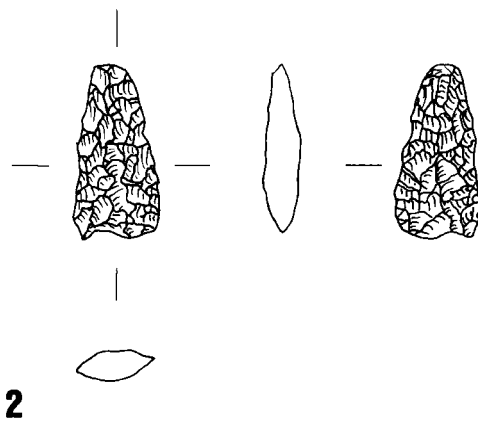
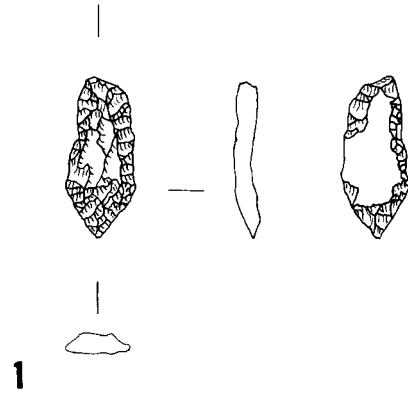

ESTAMPA 20 – Negrais. Pedra lascada.

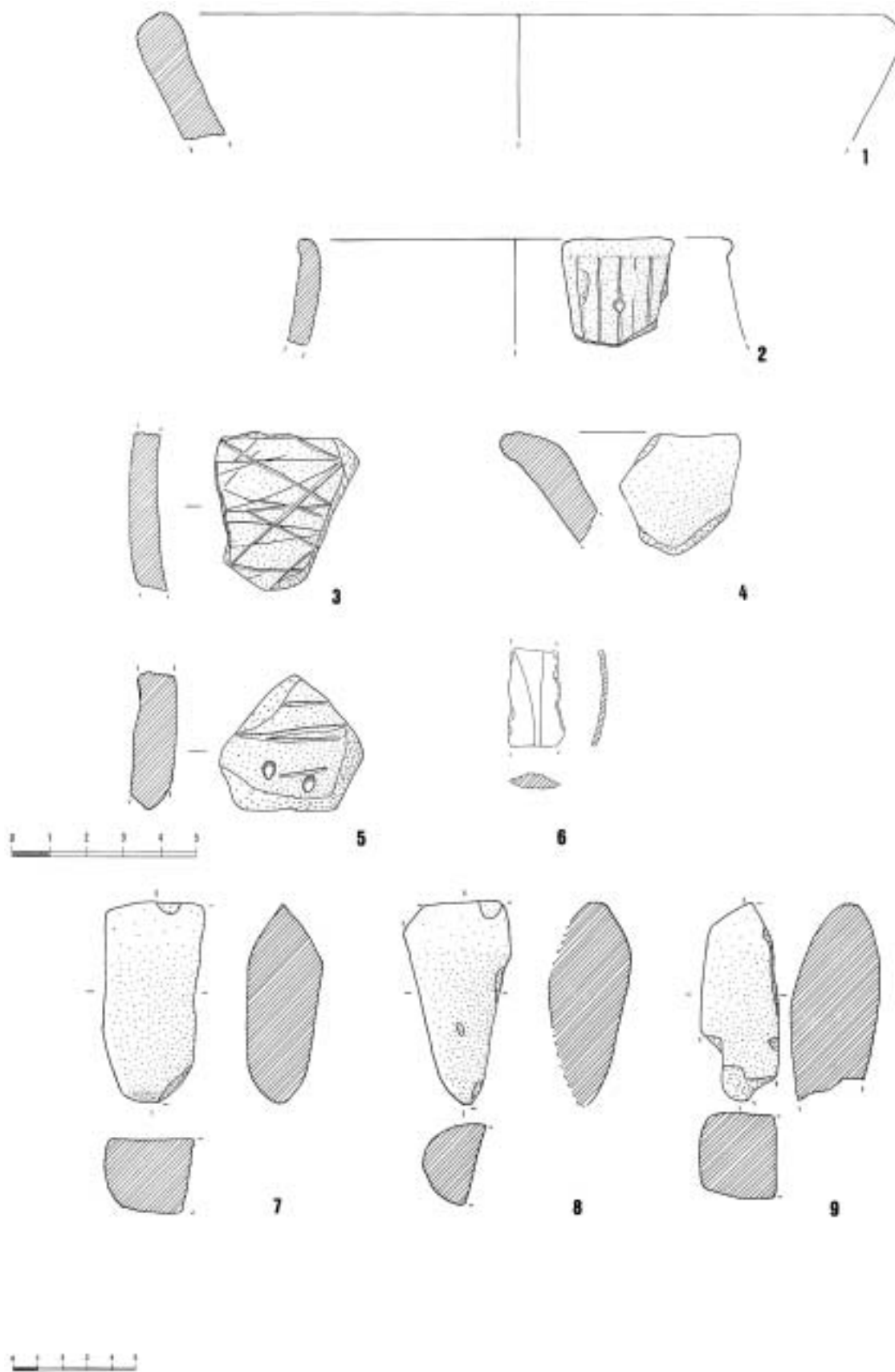

ESTAMPA 21 – Alto do Montijo (cerâmica, pedra polida e lascada).

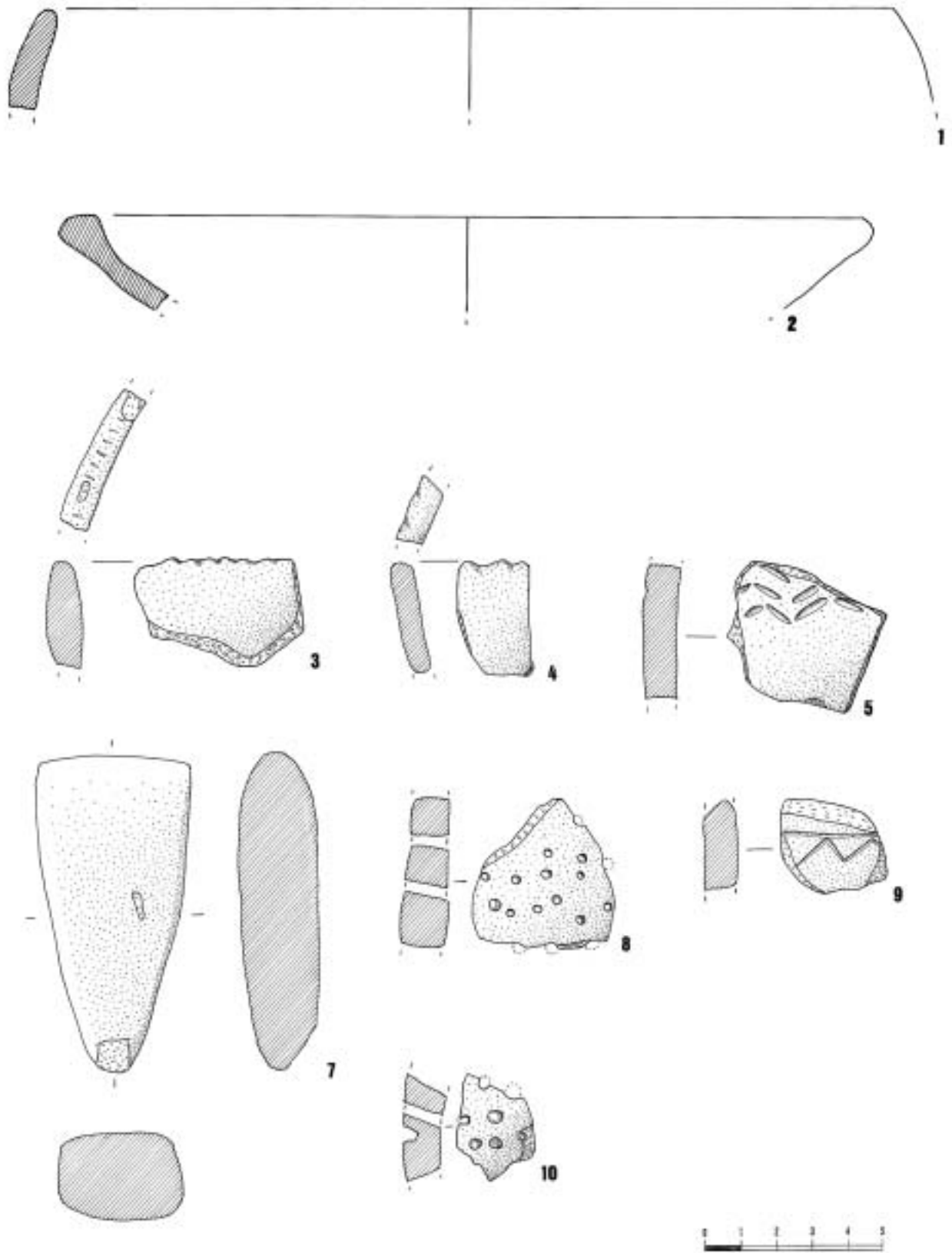

ESTAMPA 22 – Barreira (cerâmica, pedra lascada e polida).

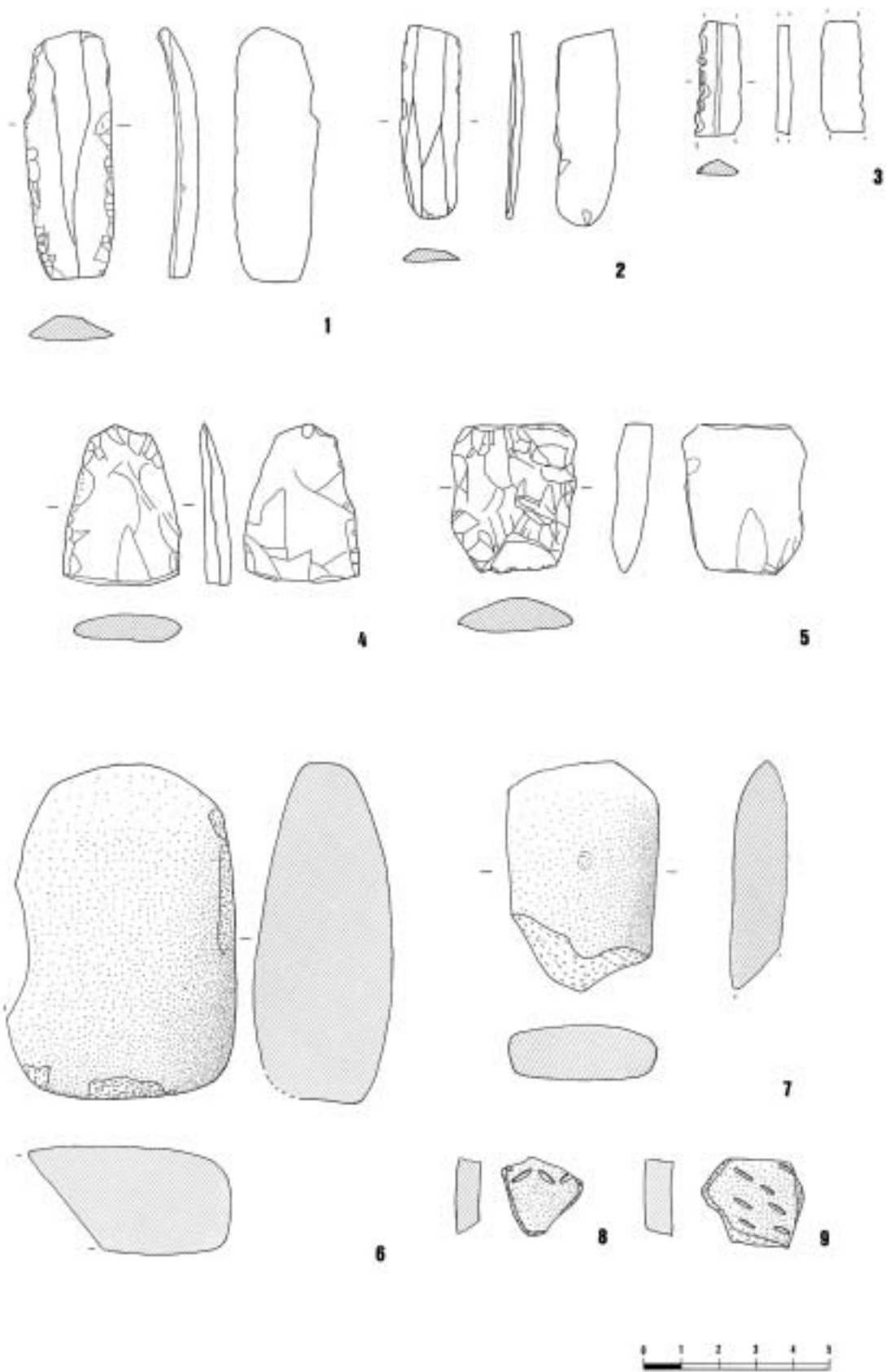

ESTAMPA 23 – S. Miguel de Odrinhas (cerâmica, pedra lascada e pedra polida).



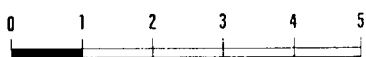
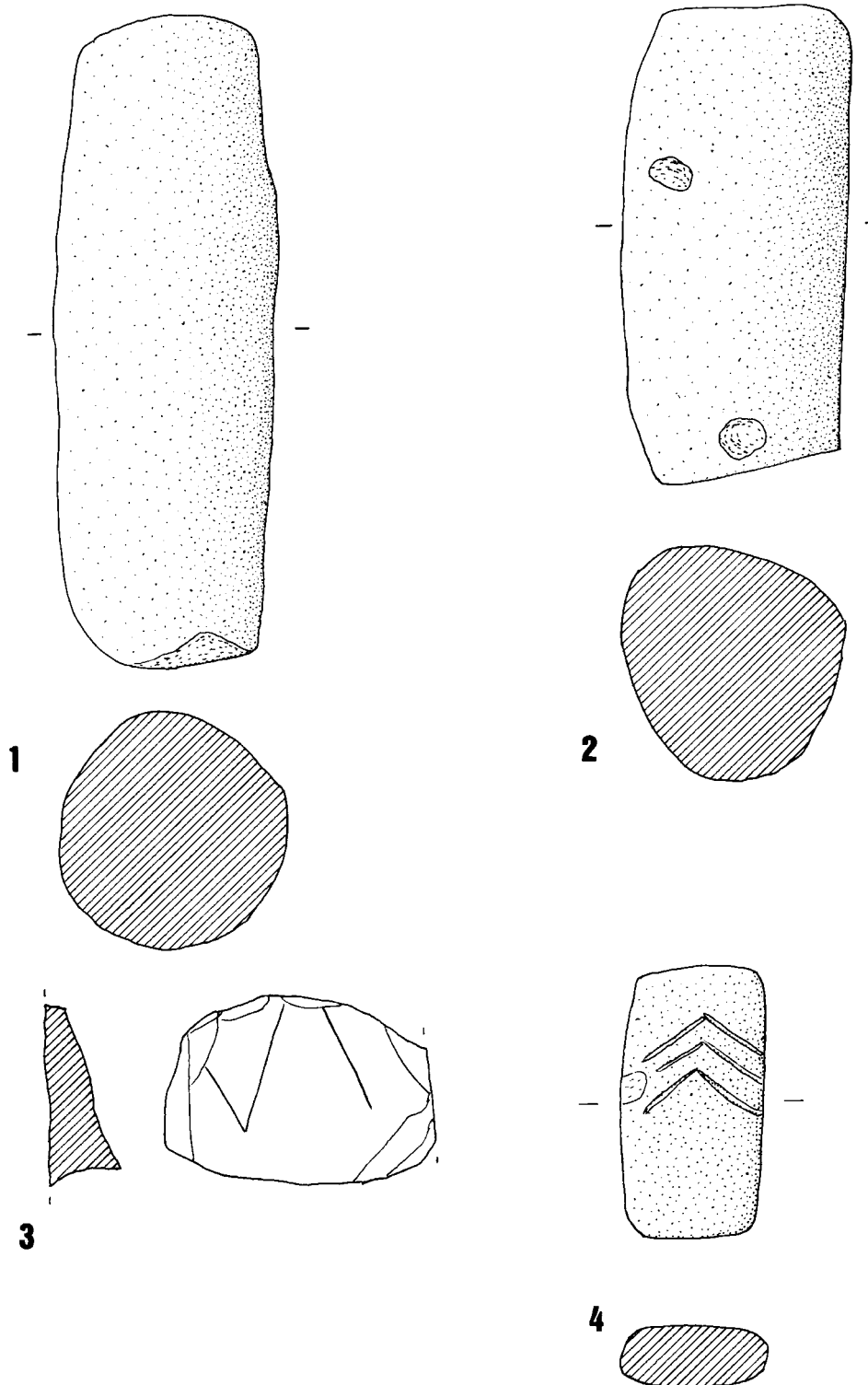

ESTAMPA 24 – Artefactos do sagrado: 1 e 2 - Penedo do Lexim, 3 - Negrals, 4 - Alto do Montijo.

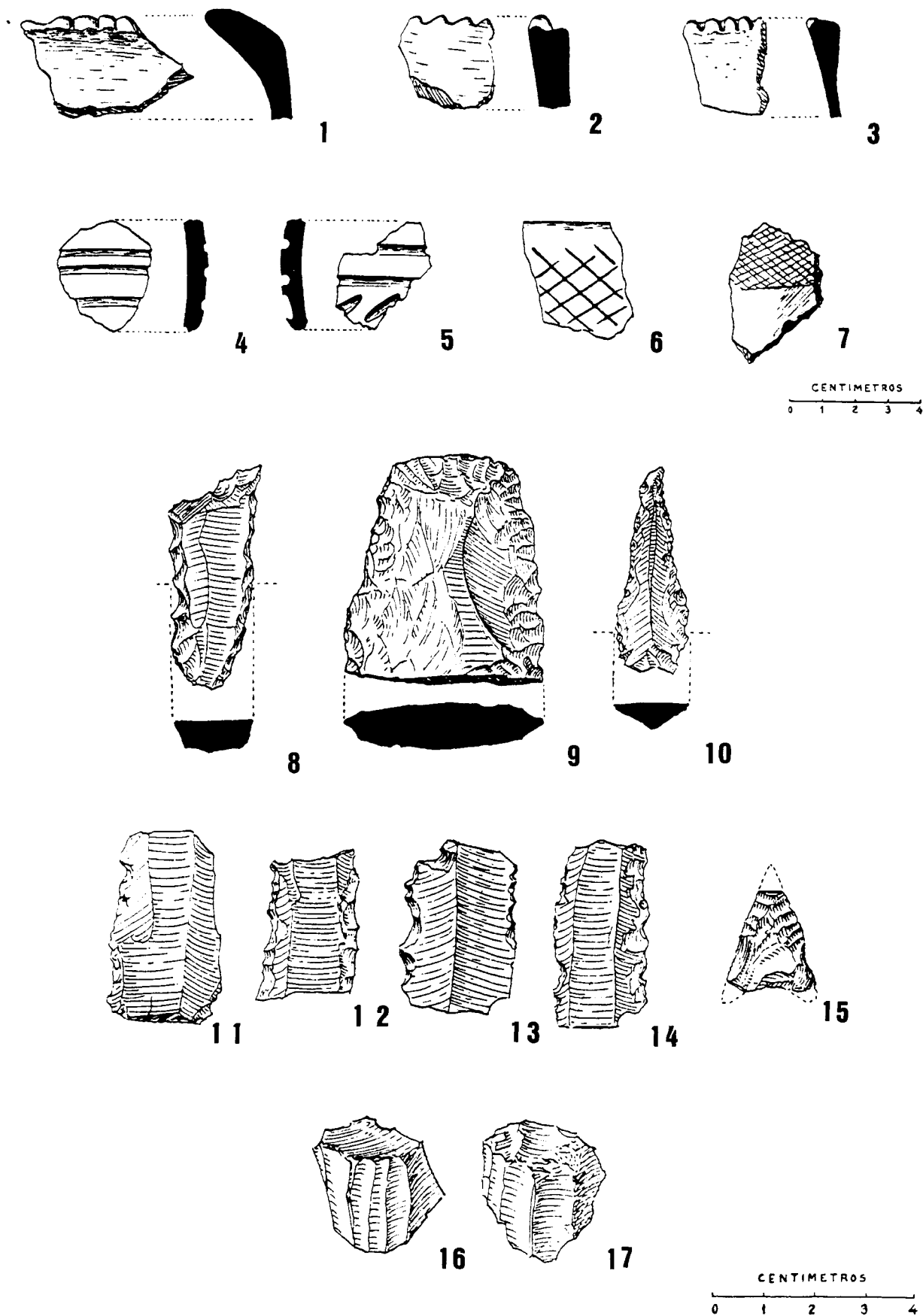

ESTAMPA 25 - Olelas segundo Serrão e Vicente, 1959a : est. X (11, 12, 13, 14), XII (16, 17), XV (1, 2, 3, 8, 9, 10, 15), XVI (4, 5), XVII (6, 7).

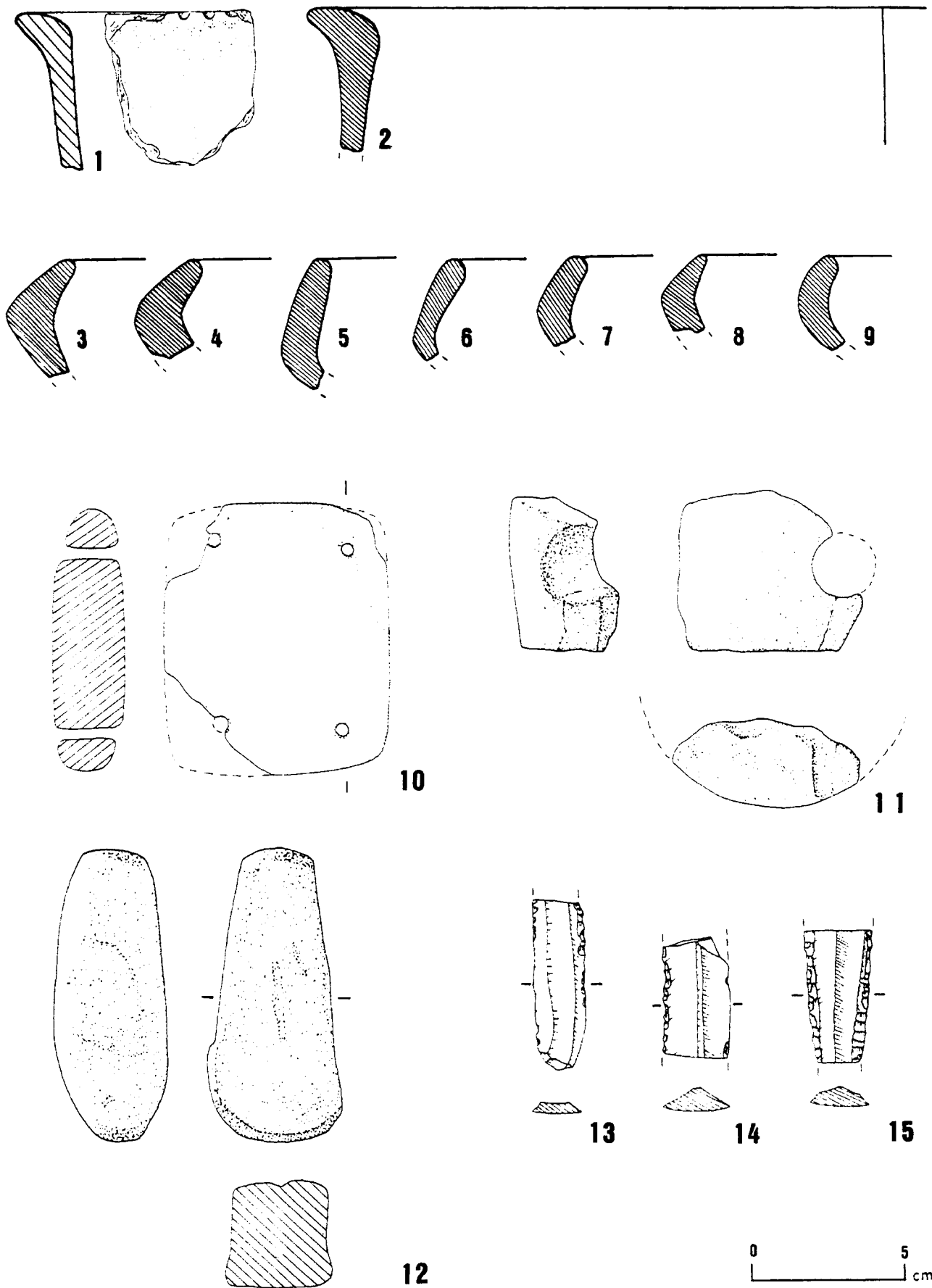

ESTAMPA 26 – Casas Velhas segundo Carreira e Lopes, 1994 : est. I (10, 11, 12, 13, 14, 15), 3 (2, 3, 4, 5, 6, 7, 8, 9), 5 (1).